

Rapid restoration of infiltration in clogged permeable interlocking concrete pavers (PICP) – proof of concepts

by

Bill James and Harald von Langsdorff

Build a better mouse trap (and the world will beat a path to your door)

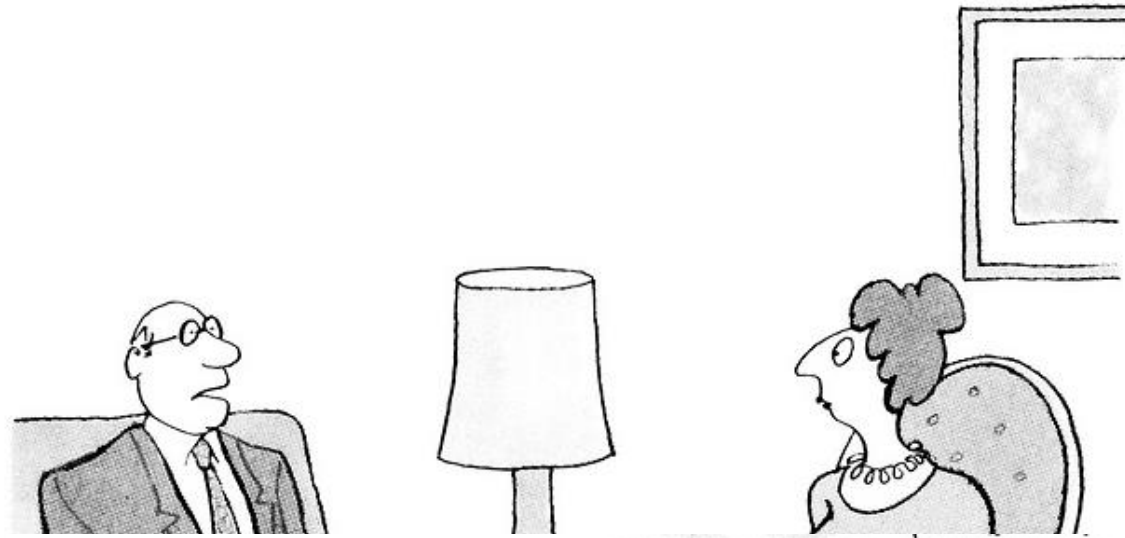

"I built a better mousetrap, and the only result was that it enabled me to trap better mice."



Outline

We describe the purpose and demonstrate the performance of a new PICP design.

Tests were conducted on a test rig and sample blocks by Bill. Harald rendered the concept practical.

This is *not* a report on completed peer-reviewed research nor of completed field trials, but just a description of experiments (plus some info from our patent).

Introduction - the PICPs

Clogging of drainage cells in PICPs is mostly in the upper layers of the filter media¹.

Cells with special *cupules* facilitate rapid and thorough removal and may be readily restored (e.g. by regenerative air street cleaning equipment operated at practical speeds).

Conduits provide the required controlled drainage flows, and the blocks meet *safety* standards for handicapped and other users.

These PICPs are designed for mass production.

Earlier Tests



We found that infiltration capacity can be regenerated by replacing media in the drainage cell (published at this conference in the mid '90s).

Reality Check



Field testing - 2002



Real life results with
typical street cleaners
were disappointing –
with limited
cleaning depths

Our
earlier
field
tests:
Cleaning



Systematic removal and
replacement of top 50 mm in
5mm layers

Clogging

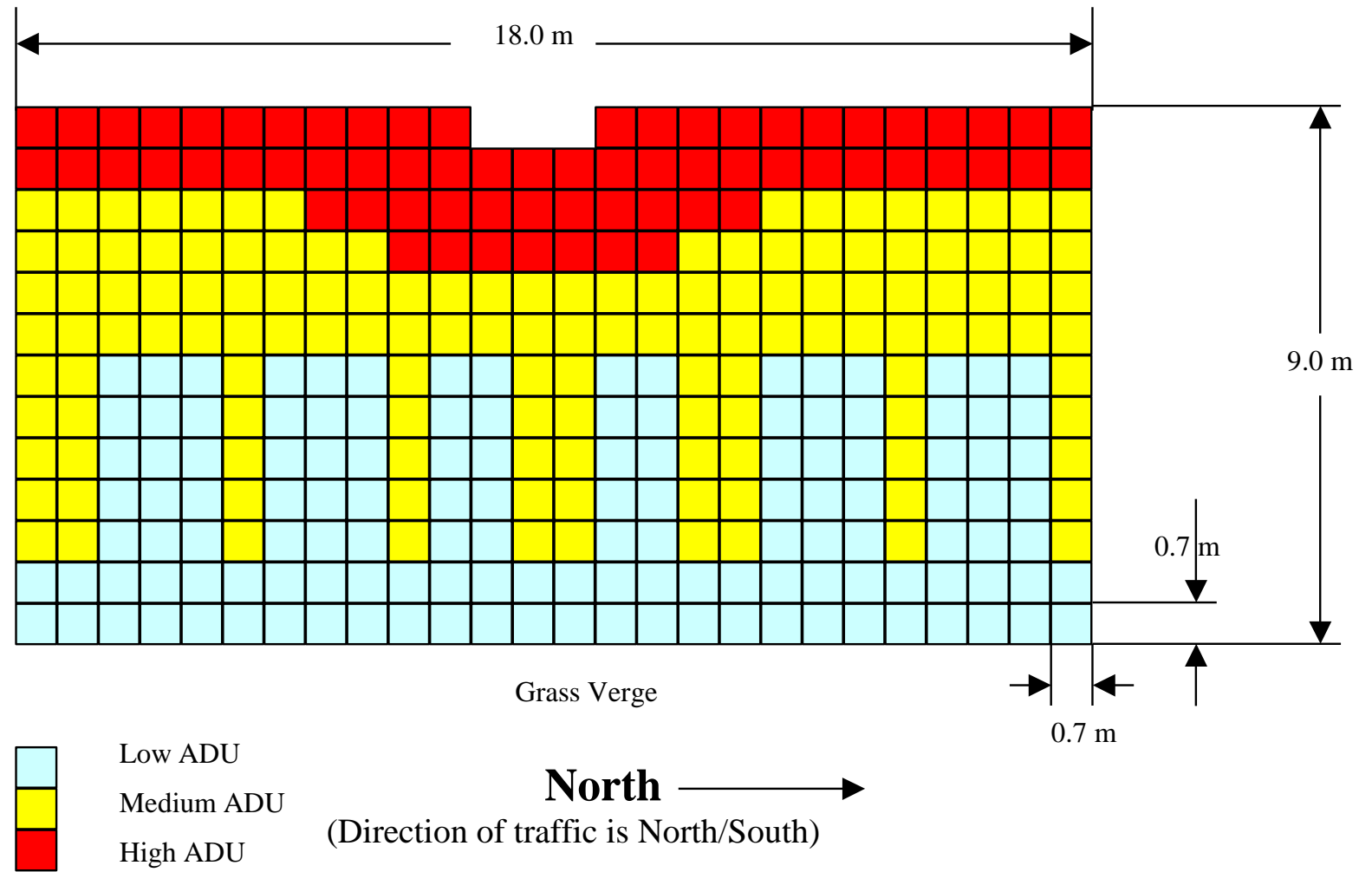

Conclusion

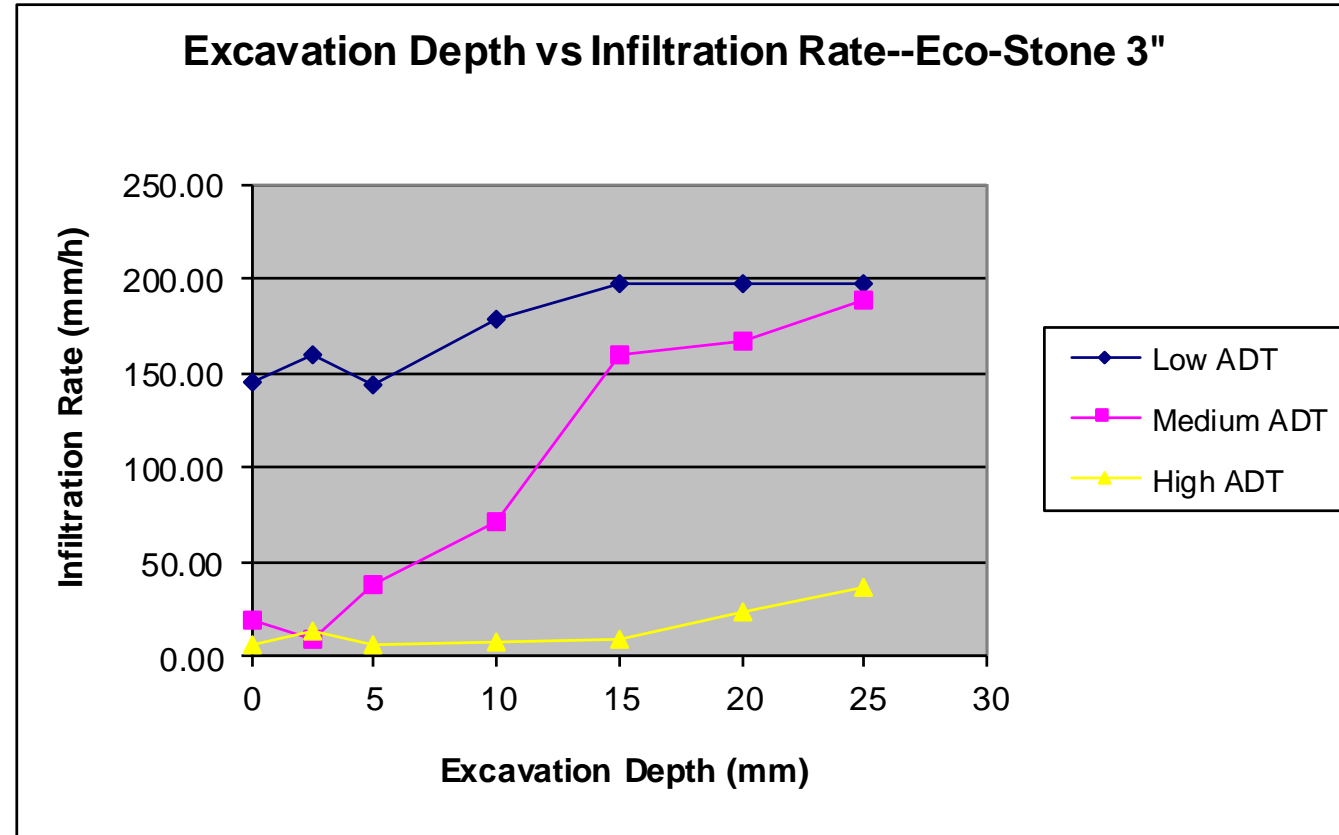

Removing filter media improves infiltration capacity. Excellent regeneration for med and low ADT, steady improvement for hi ADT.

Results

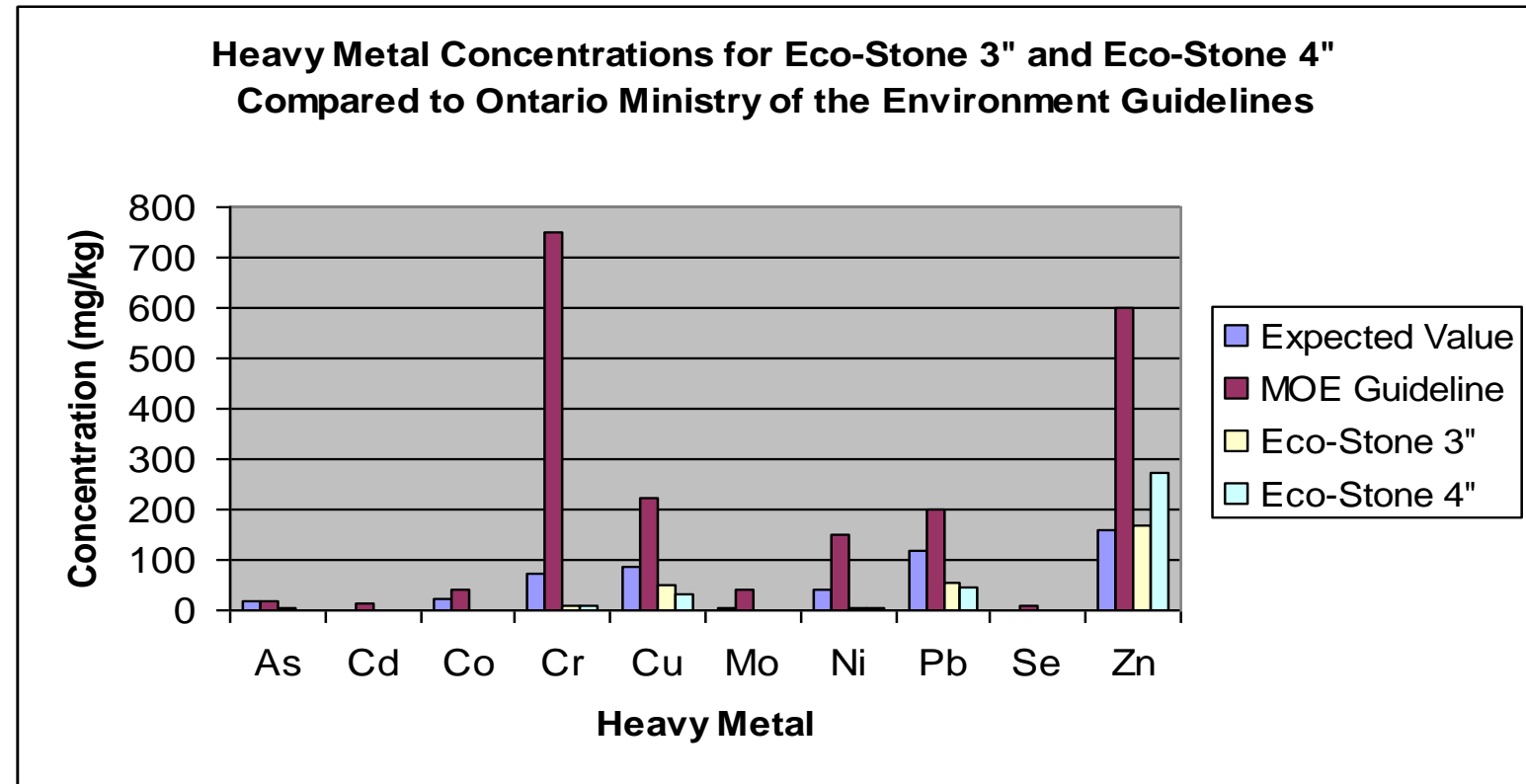

Comparison with the Ontario MOE
Guideline Concentrations for
Selected Metals in Soils

Regenerative Air Street Cleaner

How The Regenerative Air System Works

Click on the numbers to learn about each component.



- 2** This jet of air blasts down and across the pick-up head onto the pavement and into the cracks forcing up into the air stream packed-on heavy debris as well as fine dust particles.

Pick-up head, detail

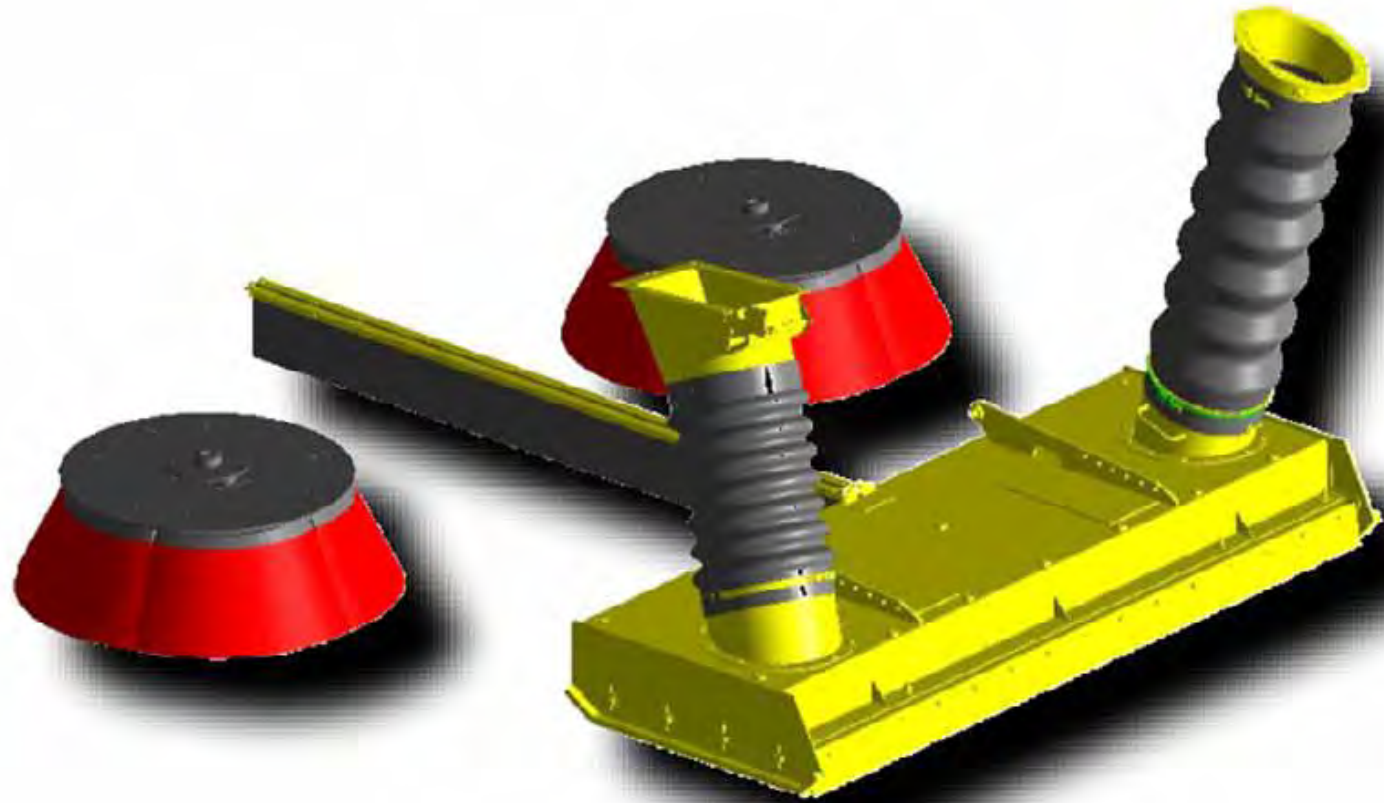

Pick-up head, general arrangement

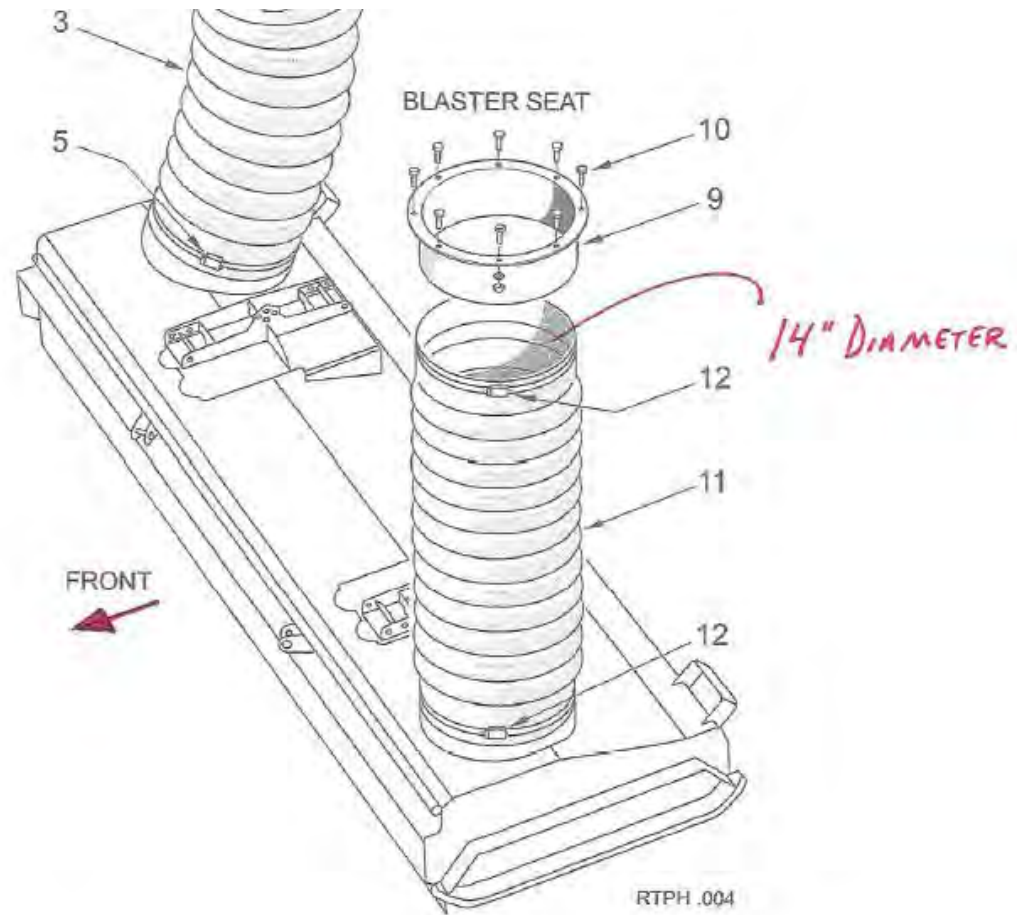

Pick-up head

Pick-up head, detail

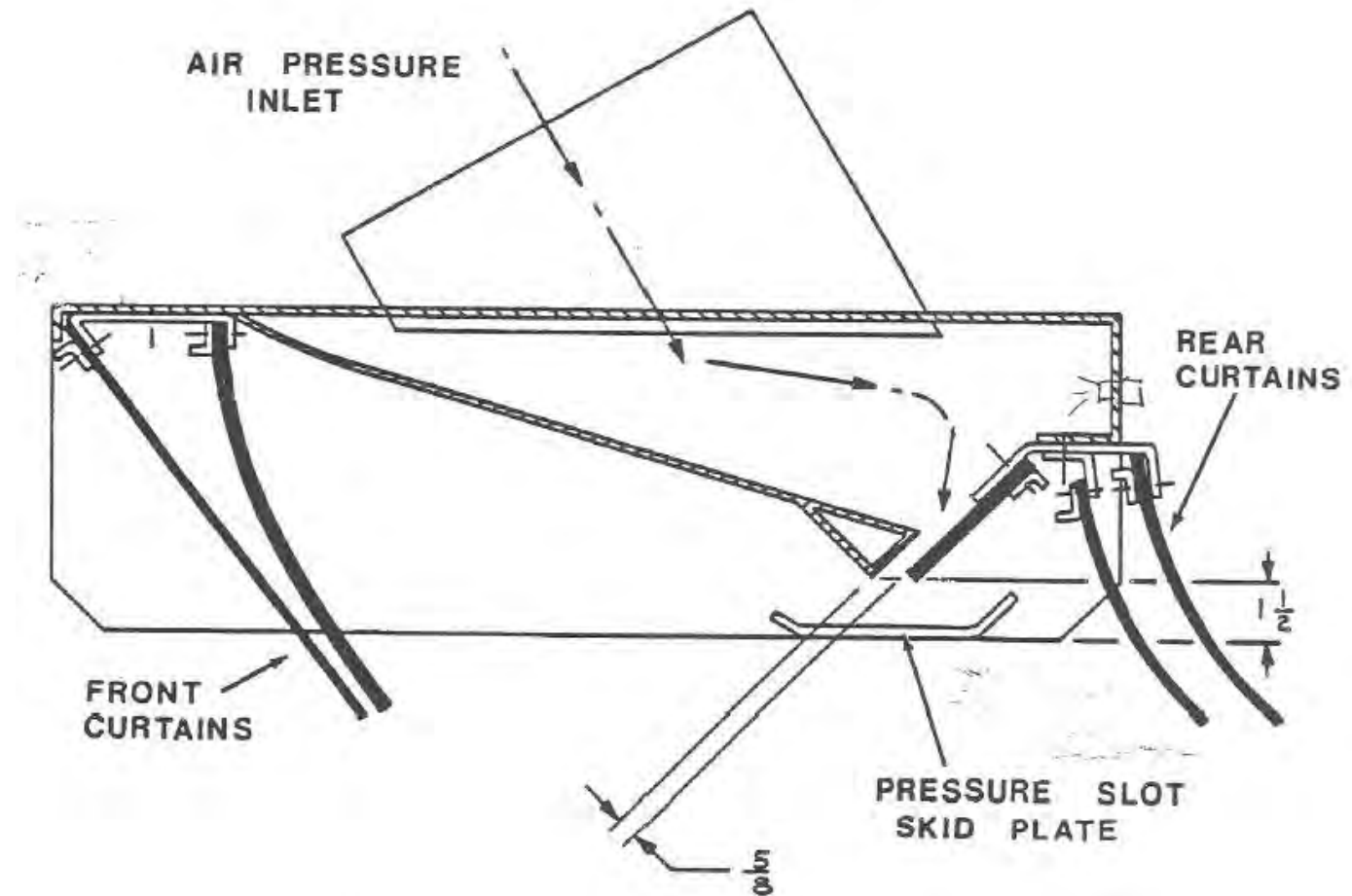

Pick-up head

Pick-up
head,
detail

Elgin – Pick Up Head Pressure Slot

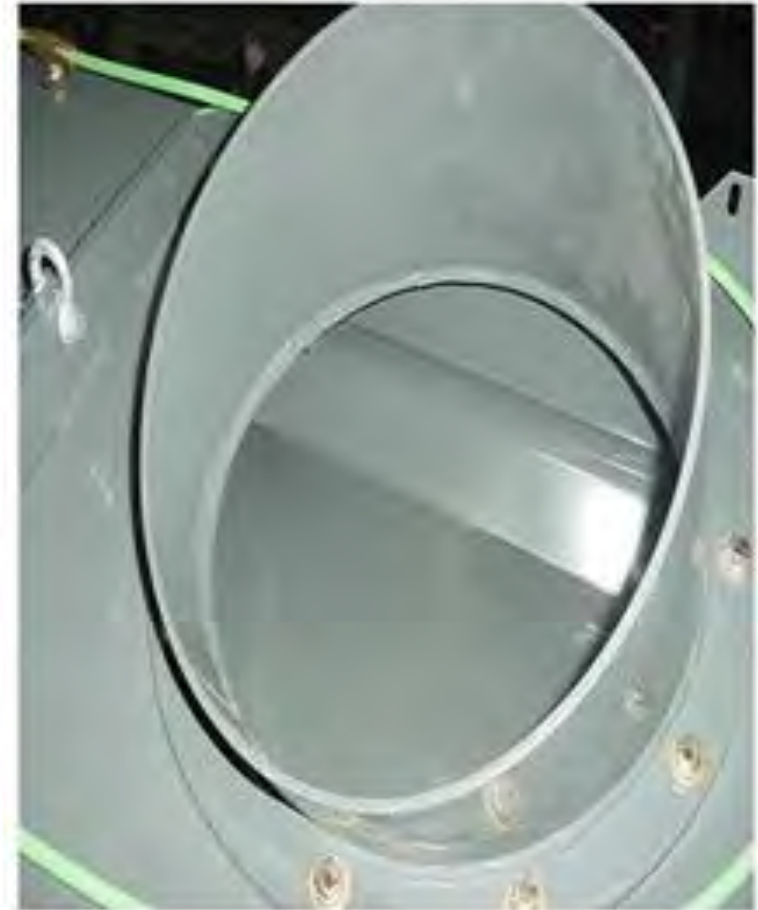

Cross-section, traditional PICP

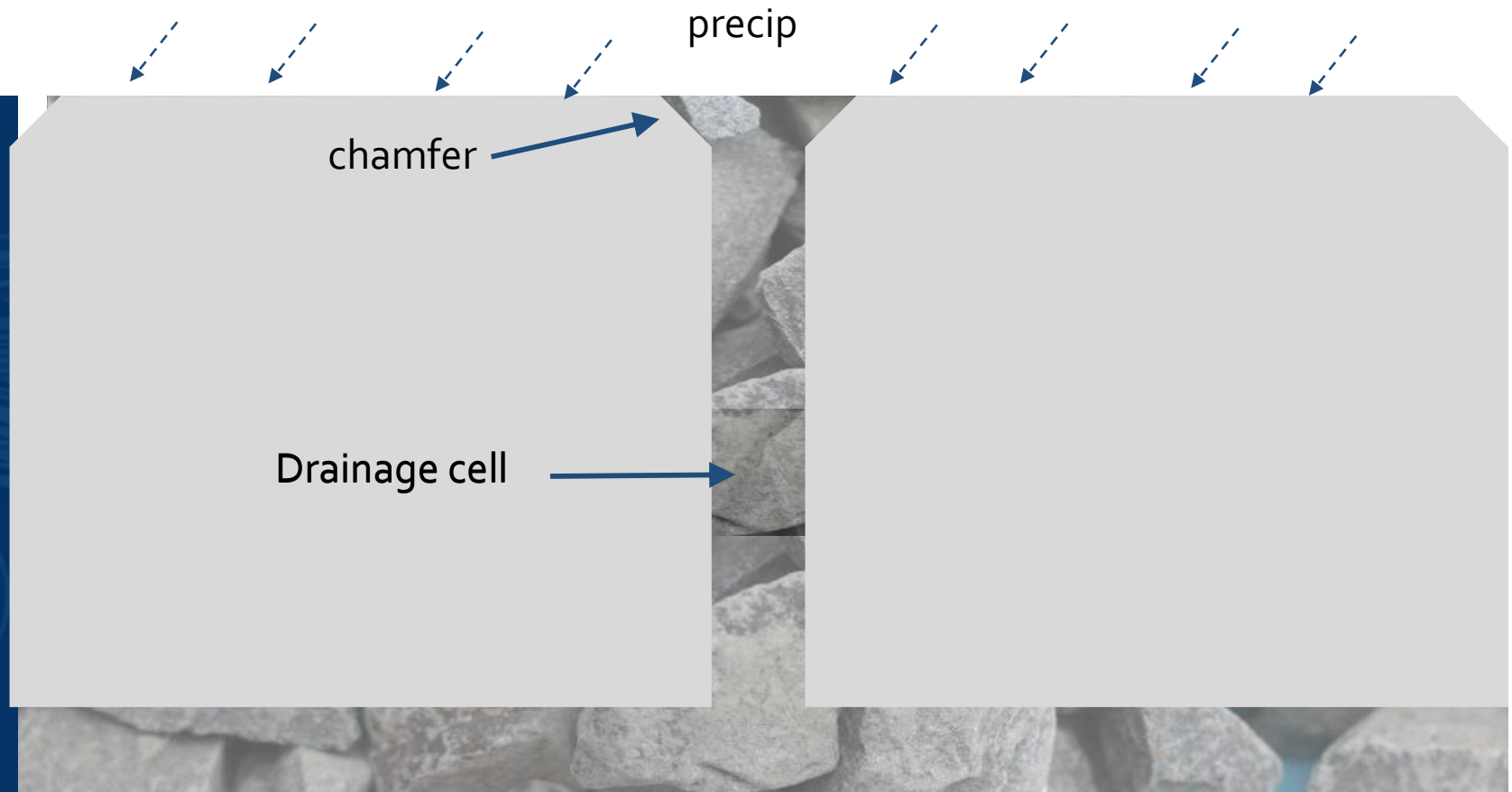

Enlarged joints or voids at the corners or sides of approximate rectangular shapes with beveled upper edge or side are filled with granular aggregate.

Previous Tests



20y of research showed that at hi ADT the upper 25mm plugs with fine debris and infiltration rate consequently decreases.

Current
technology
has limited
effect

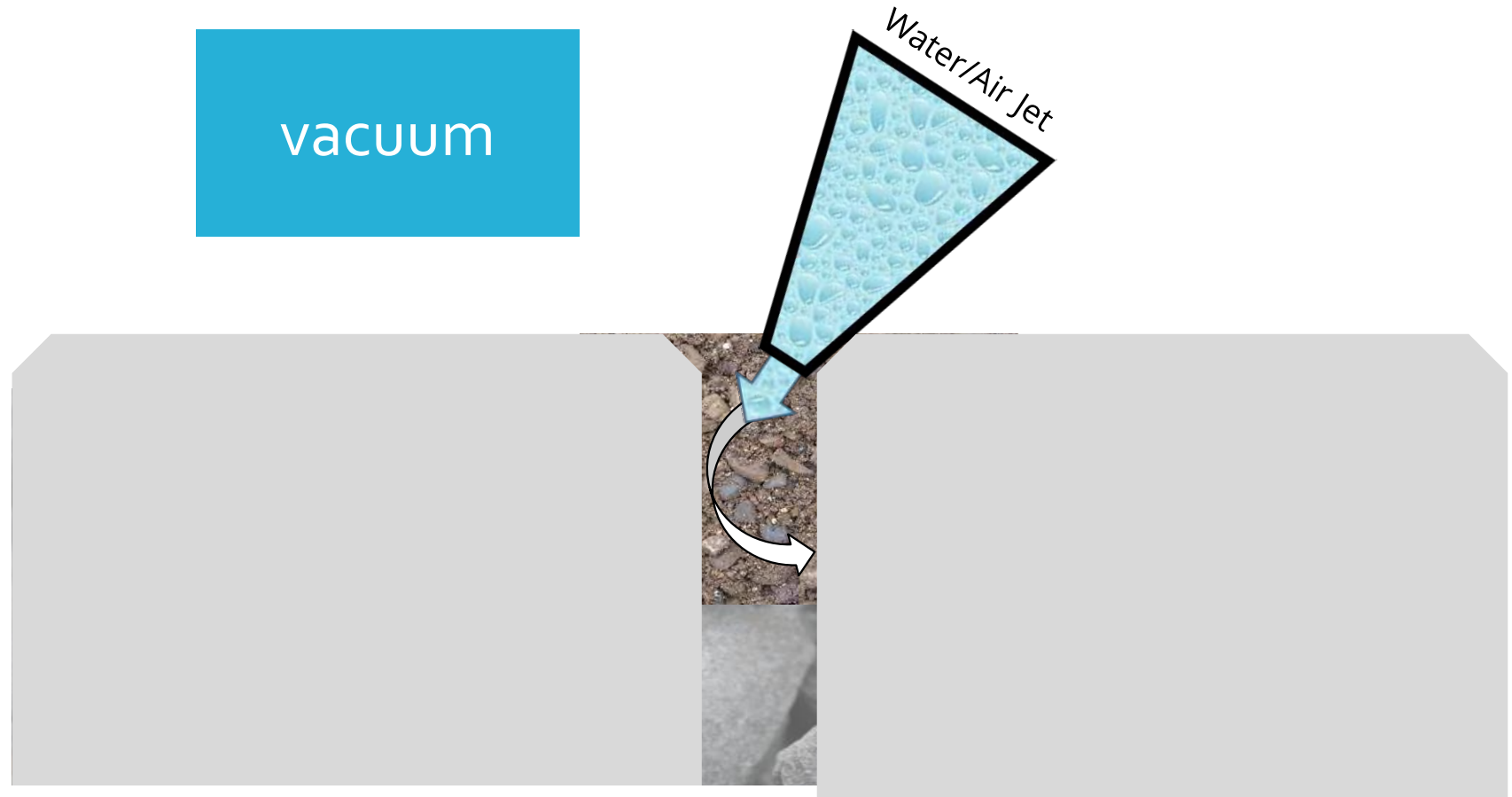

Debris and fines wedge between narrow and steep sides, brushing often pushes it further down and even vacuuming has limited effect.

Fundamentals of our suggested concept

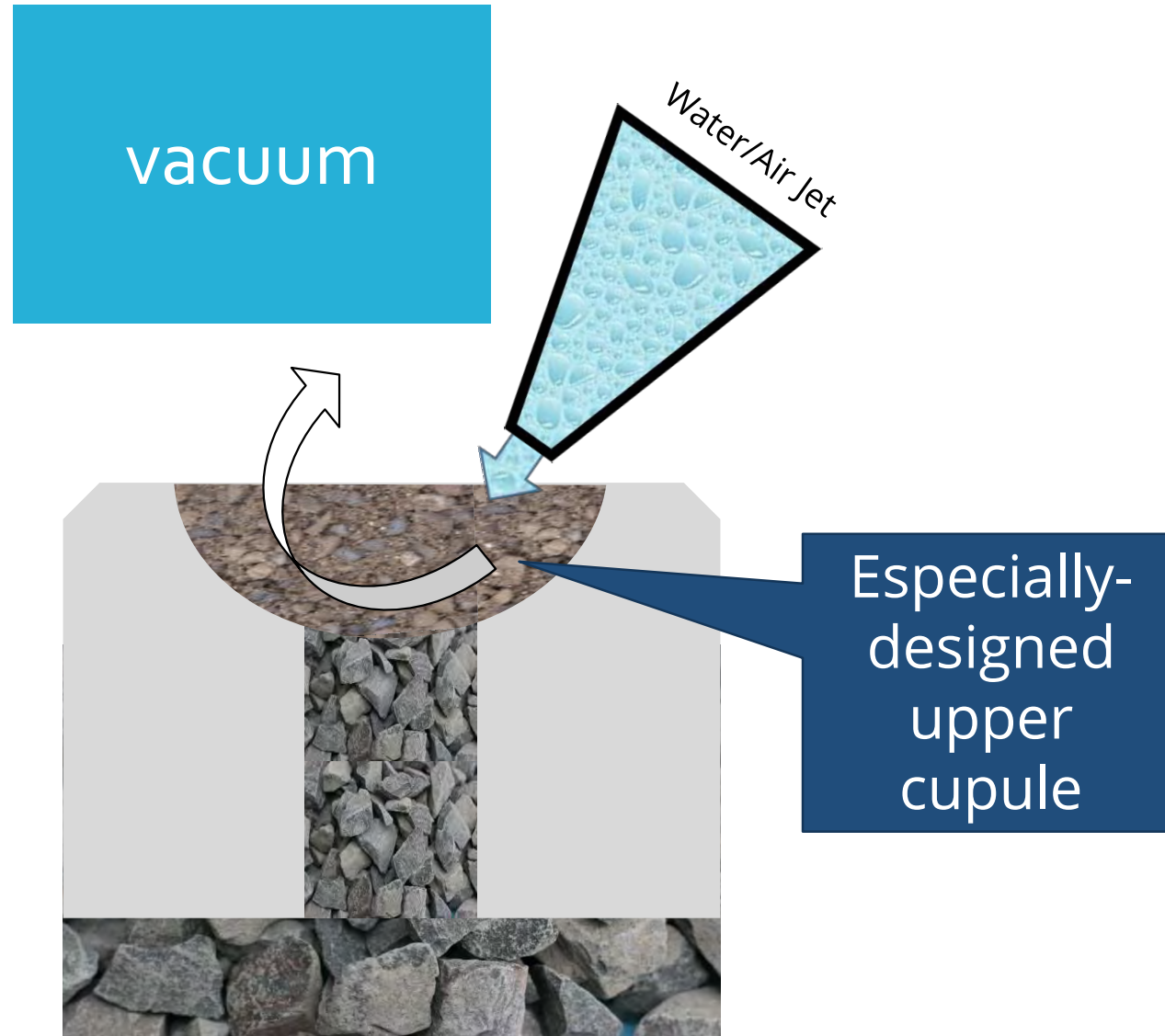

Induced turbulent vortices

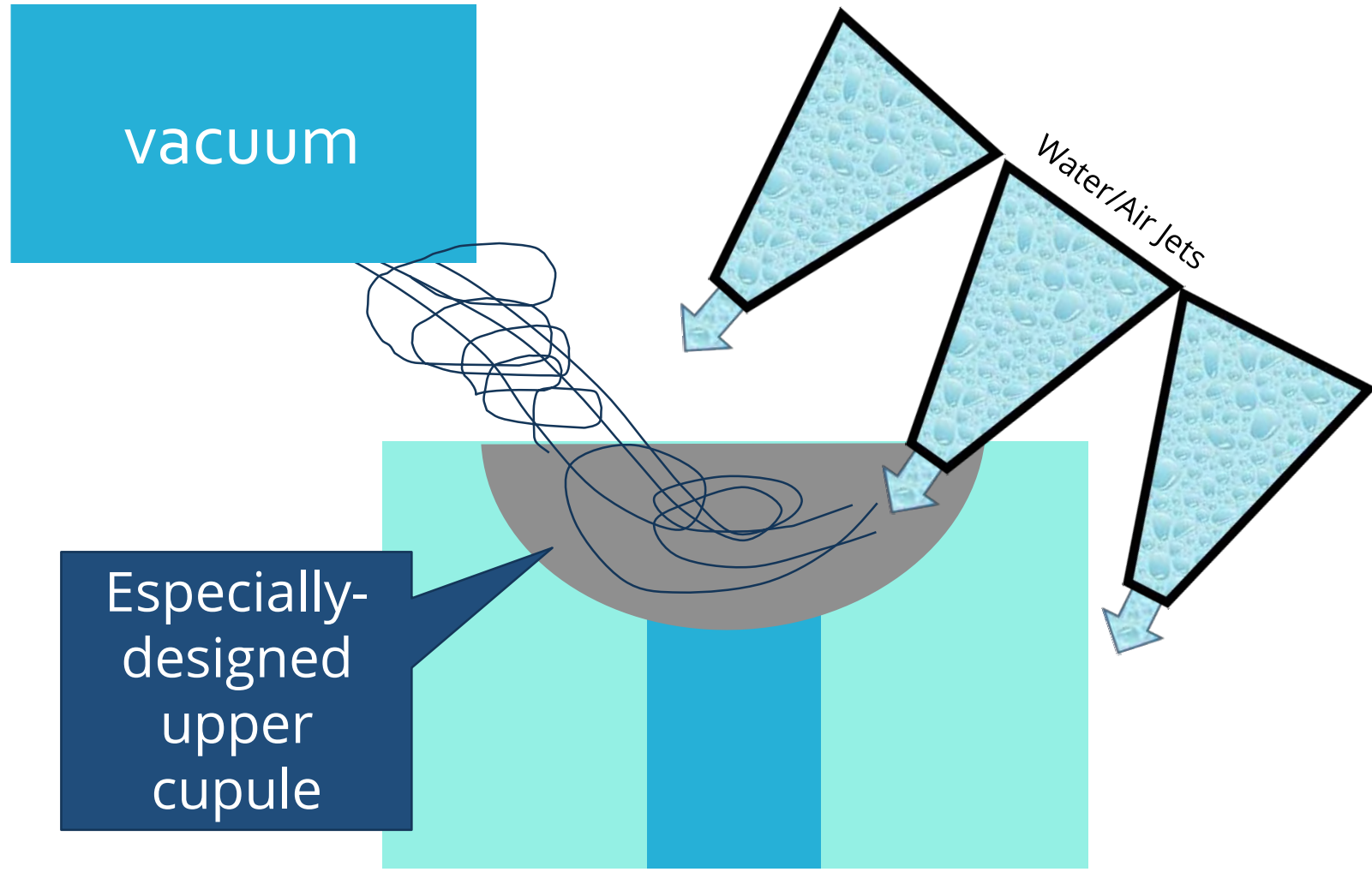

Especially-designed cupule

PICP Variations tested



Sample test blocks were fabricated in Guelph

More...

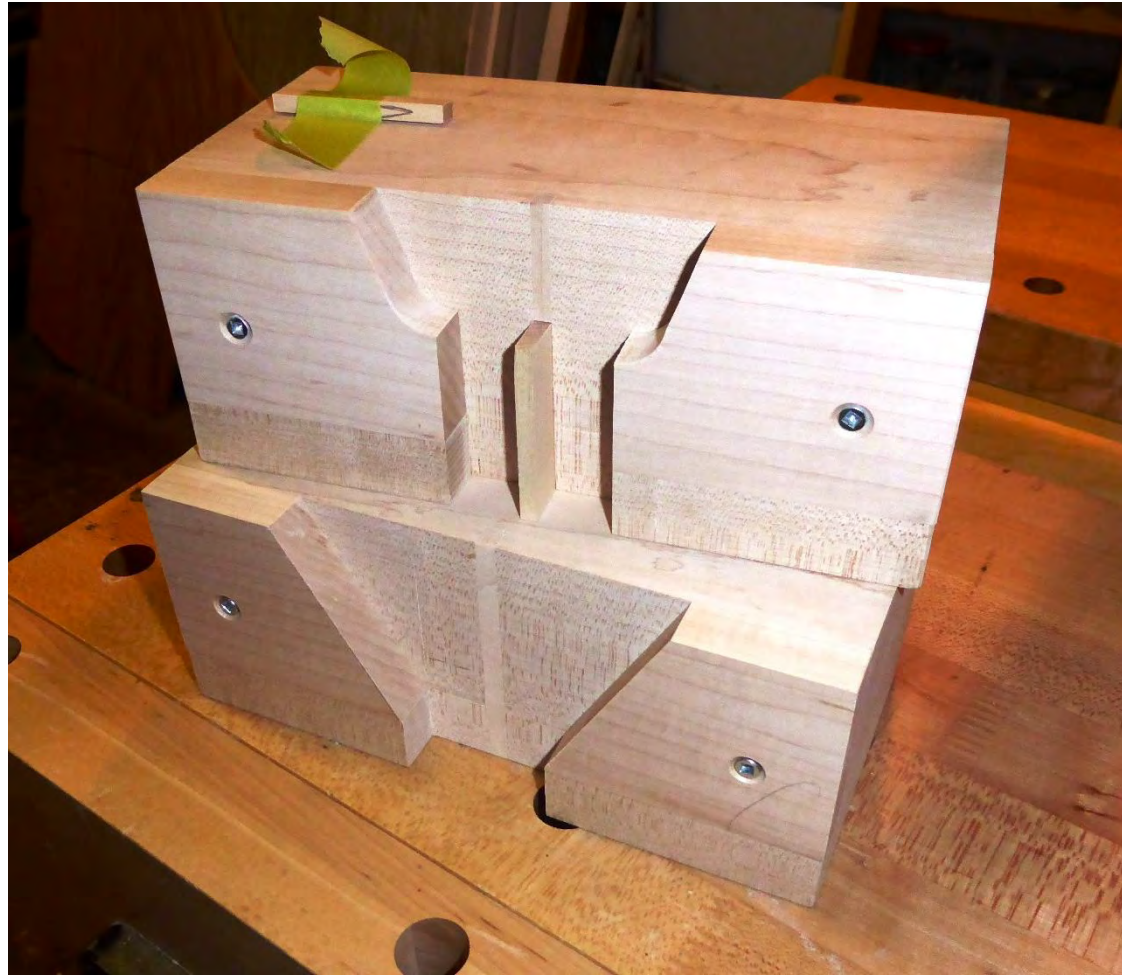

Sample test blocks were fabricated in Guelph

Graded filter media in test section



Test
section
placed in
test rig



Experiments

Preliminary results for selected geometries show removal achieved at practical speeds.

Dependent variable is:

S, ratio of mass of removed and captured to original mass of cell filter media (plus filtrate).

Current test strategy

Tests on these new PICPs are to be carried out at several universities in Southern Ontario. Independent variables are:

V , speed of cleaning equipment over the pavement;

v , air flow speed;

ϕ , angle of the cleaning jets;

p , pressure in the cleaning jets;

D, r , geometry of the cupules; and

G , gradation of the filter media.

Test rig arrangement

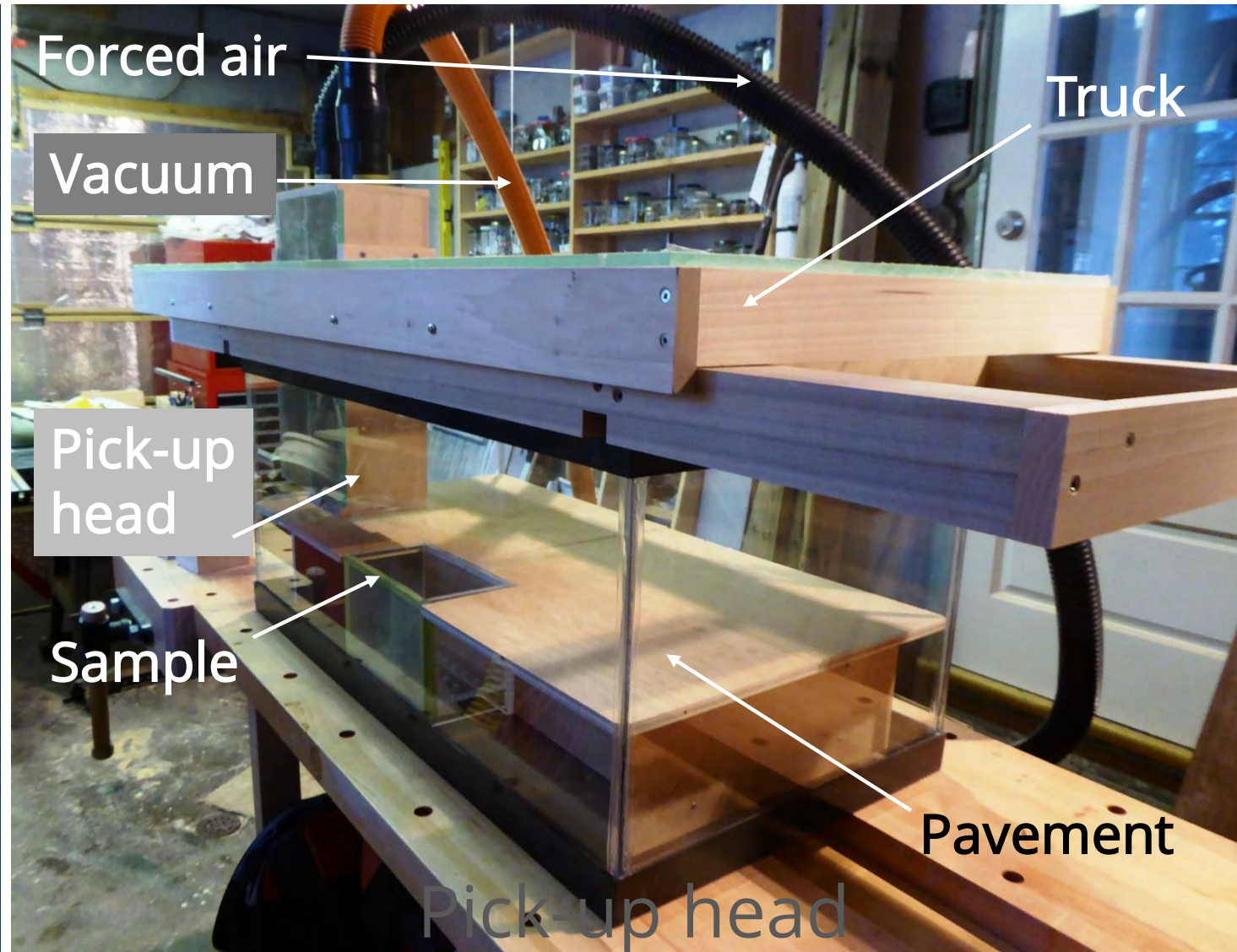

Test rig, pick-up head



20-sec
slo-mo
video



Results



Instant cleaning

Patent:
PICP made
for rapid
cleaning
and
restoring
by routine
equipment.

Main idea is special shape/radius/angles of aperture for rapid cleaning by induced vortices

Variations:

- Cell can be within a paver or at its edge ($\frac{1}{2}$ cell can be at edge of paver with the other $\frac{1}{2}$ on the adjacent paver)
- Cells can be oriented in sweeper direction
- Design, size, number and/or location of cells can be applied to various paver shapes
- Special spacer between pavers can assist cleaning, interlocking

Patent cont'd

- Pressure air/washer jet is aligned obliquely
- Enables collection & treatment of pollutants
- Used aggregate is expelled from drainage cell and collected in hopper
- Permits reuse of aggregate and water
- Allows chemical, biological and physical treatment processes, e.g. for oils/hydrocarbons, heat, enzymes, filtrate and disinfection
- Variation: Apertures are immediately refilled with cleaned or new aggregate

Conclusion

- Essential result of this research is that particulates and pollutants associated with them are easily captured by traditional street cleaning of these PICPs.
- Cleaning and restoration is fast and effortless.

Not-so-distant outlook

Easy removal of debris and fines loaded with pollutants will allow:

- rapid regeneration of infiltration rates;
- pollutant trapping; and
- recycling of filter media.

Thus these special permeable concrete block pavers will hopefully advance environmental protection.

THANKS FOR MAKING THAT PRODUCT MOCK-UP LAST WEEK. THE CUSTOMER LIKED IT SO MUCH THAT HE ORDERED A THOUSAND!



S. Adams

THAT WAS A MOCK-UP! WE DON'T MAKE THAT PRODUCT YET. IT WOULD TAKE THREE YEARS TO MAKE ONE.



JUST GIVE ME A THOUSAND MOCK-UPS. THE FIRST ONE WAS TERRIFIC!



THE MOCK-UP WAS OUR IDEALISED PRODUCT WITH DUCT TAPE OVER THE HOLES



7/9/86 © 1986 United Feature Syndicate, Inc.(NYC)

Thanks!

Hope you're somewhat impressed.